

USWN870RBW
USWN870RBE
USWN870RB

Wall Hung Urinal
w/ Built - in Sensor



Features

- Compact design with privacy shields
- CeFiONtect technology - super smooth, ion barrier glazing for a clean urinal
- Water saving effect with powerful flushing action
- Self- Powered type available
- Integral trap
- Easy and flexible installation

Specifications

Water Use : 1.2 ~ 1.9L
Size : 400W X 365D X 836H
Water Pressure : 0.1MPa ~ 0.75MPa



USWN870

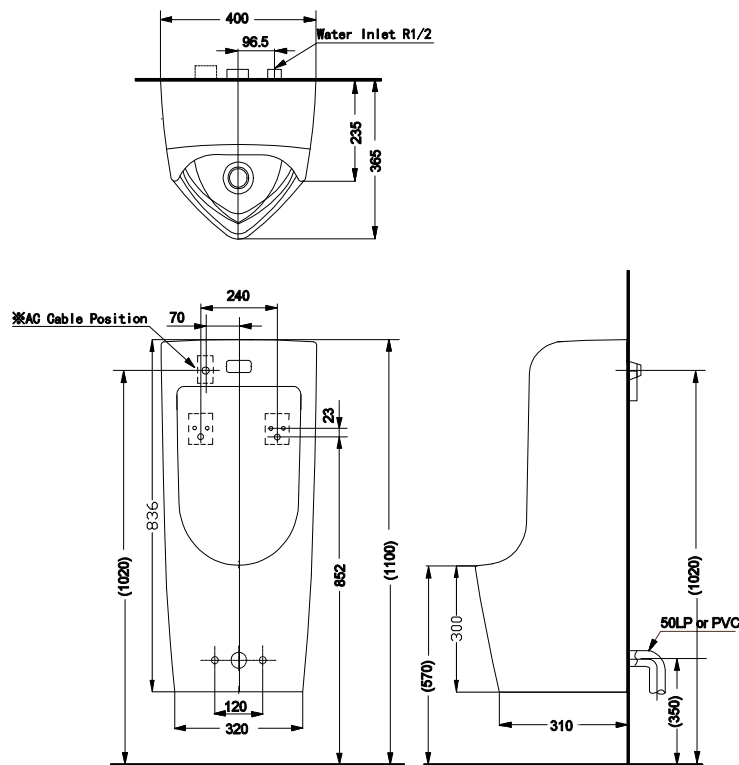

* For USWN870RBE

() Recommended Dimension

Parts description

Fittings included.

- **USWN870RBW**
Wall Hung Urinal Back Inlet Type
W/ Built-in Sensor
Self-powered Operated
- **USWN870RBE**
Wall Hung Urinal Back Inlet Type
W/ Built-in Sensor
AC 220V Operated
- **USWN870RB**
Wall Hung Urinal Back Inlet Type
W/ Built-in Sensor
Battery Operated

Colors

White

Please consult a TOTO representative for details